



SEATS AND STOOLS

Quality Chairs, Barstools and Replacement Seats and Backs

Upholstered Breuer Replacement Seat and Back Instructions

If you are replacing both your Breuer seats and the backs, Remove the seats AND the backs ATTACH THE BACKS FIRST

Instructions For Attaching New Breuer Backs

1. Measure the distance from the top of your existing chair to the floor.
2. With no seat and back on frame take a belt or a rope and pull top posts together to 15" between center of screw hole to center of screw hole.
3. Hold new back at same distance from top to floor. Center back and attach one screw on left side then one on right side. Attach 2 remaining screws.
Note: A little soap on the screw threads is a big help. (**Caution: Do not over tighten screws.**)

Your new Breuer replacement back is ready to use.

—

Instructions For Attaching New Breuer Seat

1. Place your seat upside down (as shown) on a flat surface (corner of a table). Position your chair frame with the front of the replacement.
2. Make very small guide holes in bottom of seat with a nail or drill bit before fastening seat with screws to ensure easier assembly.
3. Secure the seat to frame using original four (4) screws. Note: A little soap on the screw threads is a big help (**Caution: Do not over tighten screws.**)

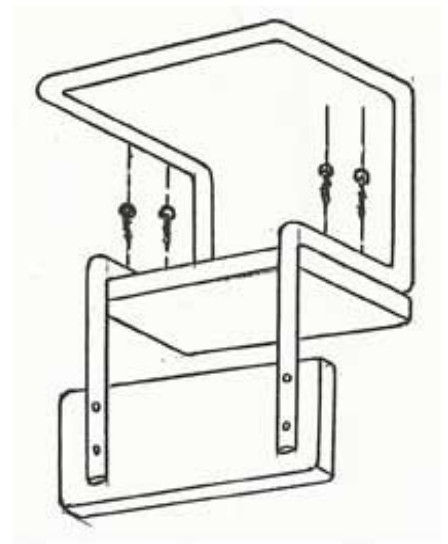

Your new Breuer replacement seat is ready to use.

Any questions or problems please call: 1-866-967-3287
Breuer Seats by SeatsandStools.com